

---

# IMPRECISION IN ENGINEERING DESIGN

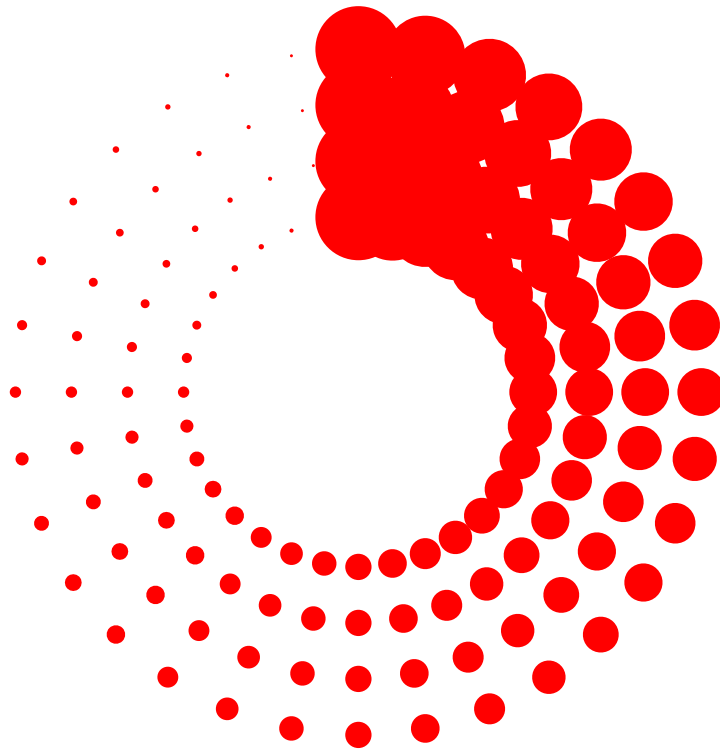



# IMPRECISION IN ENGINEERING DESIGN

Edited by

**ERIK K. ANTONSSON, Ph.D., P.E.**  
Executive Officer and Professor of Mechanical Engineering



**Engineering Design Research Laboratory**  
Division of Engineering & Applied Science  
California Institute of Technology  
Pasadena, California, U.S.A.



## Chapter 1

# COMPUTATIONS WITH IMPRECISE PARAMETERS IN ENGINEERING DESIGN: BACKGROUND AND THEORY

Kristin L. Wood and Erik K. Antonsson

*ASME Journal of Mechanisms, Transmissions, and Automation in Design*  
Volume 111, Number 4 (December 1989), pages 616-625.

### **Abstract**

A technique to perform design calculations on imprecise representations of parameters has been developed and is presented. The level of imprecision in the description of design elements is typically high in the preliminary phase of engineering design. This imprecision is represented using the fuzzy calculus. Calculations can be performed using this method, to produce (imprecise) performance parameters from imprecise (input) design parameters. The Fuzzy Weighted Average technique is used to perform these calculations. A new metric, called the  $\gamma$ -level measure, is introduced to determine the relative coupling between imprecise inputs and outputs. The background and theory supporting this approach are presented, along with one example.

## **1. Introduction**

Engineering design, both in practice and research, is evolving rapidly, especially in the development of computer-based tools. Emphasis is moving from the later stages of design, to computational tools for preliminary design. In an earlier paper [33], a general approach to computational tools in preliminary engineering design and a model of the design process was described. The primary aim of this model is to provide a structure for the development of tools to assist the designer in: managing the large amount of information encountered in the design process; determining a design's functional requirements and con-

straints; evaluating the coupling between the design parameters; and carrying out the process of choosing between alternative design concepts.

We are particularly interested in developing tools to assist the designer in the *preliminary* phase of engineering design, by making more information available on the performance of design alternatives than is available using conventional design techniques. The most important design decisions (and potentially the most costly, if wrong) are made at the preliminary stage. Our hypothesis is that increased information, over what is available by traditional design methods, will enable these decisions to be made with greater confidence and reduced risk. The effect will be greater, the earlier in the design cycle additional information can be made available.

The preliminary phase of the engineering design process is one that embodies many functions: concept generation; evaluation of imprecise descriptions of simplified versions of the design; judgement of design feasibility; etc. [26, 15, 28]. The concept generation and simplification processes will not be addressed by the research reported here, rather our aim is to provide a technique for representing, manipulating, and evaluating the approximate, or imprecise, parametric descriptions of the (preliminary) design artifact.

Typical examples of imprecise descriptions in preliminary design include: an irregular cross-section structural member may be represented by a rectangular section for the purposes of initial evaluation; a gear set may be represented by a pair of circles rolling on each other (without slip), and an approximate speed ratio; a length of shaft may be represented as “about 25 cm”; etc. These are approximate, or *imprecise*, descriptions of the design artifact, not incomplete descriptions. The gear set, imprecisely represented above, has all of the *functional* attributes of a gear set, but none of the detail.

As the design process proceeds from the preliminary stage to more detailed design and analysis, the level of imprecision in the description of the design artifact is reduced. Naturally at the end of the design cycle, the level of imprecision is very small, although uncertainties (e.g., tolerances) remain. It is this spectrum of levels of precision that characterizes progress through the design process, from a description of a need, to a (precise) description of a device to fulfill that need.

Unfortunately it has been difficult to provide computational tools for the preliminary phase of the design process, largely because of the relative paucity of algorithms and techniques that can operate on imprecise data. Solid modeling, optimization, mechanism analysis, and other CAD methods all require a highly precise representation of the objects being designed. This paper presents a novel (to the engineering design process) application of a method for represent-

ing and manipulating imprecision.<sup>1</sup> This technique calculates the approximate output quantities from the imprecise input parameters for each of the design alternatives, and determines the qualitative relations between the input parameters and the performance parameters (outputs). The designer is able to rank the input parameters according to their impact on the performance parameters, and to rate a design alternative according to its merit in relation to the others under consideration.

These computational tools are for use in the preliminary and conceptual synthesis stages of design, but do not attempt to supplant the designer. The idea is not to fully automate the design process, nor to automatically generate design alternatives, rather it is to make it easier for the designer to evaluate more alternatives in less time, and to provide more information on the performance of each of those alternatives. These developments form a *semi-automated* approach to design.

Terminology used to describe the design process will be defined first, background and theory as it is applied to engineering design will be presented next, followed by an example.

## 2. Terminology

### 2.1 Design Definitions

**Parameter:** A variable or quantity used in the design process.

**Design Parameter [DP]:** Any free or independent parameter whose value is determined during the design process.  
(synonyms: Design Variable, Input Parameter).

**Performance Parameter [PP]:** Any parameter used in the design process that has a specified value [FR] determined independent of (and usually in advance of) the design process. The performance parameters [PPs] are usually dependent on the design parameters [DPs], and possibly some other PPs.

**Output Parameter [OP]:** Any parameter used in the design process that is dependent on the design parameters [DPs], and possibly some performance parameters [PPs], but has no specified functional requirement [FR] value.

**Functional Requirement [FR]:** A value, or range of values, or fuzzy number that is the specified value for a Performance Parameter [PP].

---

<sup>1</sup>Fuzzy sets have been applied to other domains including: seismic risk analysis [8, 6, 7, 9, 18], optimization [13, 29], reliability [24, 37], expert systems [25], logic and decision support [1, 2, 3, 4, 17, 19, 36, 41, 39], language and grammar [17, 21, 42], and others.

#### 4 IMPRECISION IN ENGINEERING DESIGN

This value is determined independent of (and usually in advance of) the design process. Each Performance Parameter has a FR.

(synonyms: Performance Specification, Constraint).

(Note that this distinction between the Performance Parameter and its specified value [Functional Requirement] is to permit a Performance Parameter not to be identically equal to its specified Functional Requirement value at all times during the design process.)

**Performance Parameter Expression [PPE]:** An expression, relationship, or equation relating some or all of the Design Parameters to a Performance Parameter. Each PP has a PPE.

### 2.2 Fuzzy Set Implementation Definitions

**Support:** A crisp set of all values of a fuzzy set where the membership is greater than zero. Alternatively: The range of parameter values over which the fuzzy set membership is greater than zero.

**Imprecision:** The range (support) or spread of values about the peak [preference of one (1)] of a parameter's fuzzy set. The greater the imprecision, the greater the spread on the left or right (or both) sides of the preference function. This is loosely analogous to variance in the stochastic sense.<sup>2</sup> The interpretation of Imprecision, as used in design, will be discussed in the next section.

## 3. Background

Most of engineering, particularly design, can best be represented with some level of imprecision or approximation. According to Goguen [20]:

*“Fuzziness is more than the exception in engineering design problems: usually there is no well-defined best solution or design.”*

The imprecision that is being represented and manipulated by the technique reported here is meant to capture the approximations made during the early phases of engineering design.

---

<sup>2</sup>The mathematics of fuzzy sets are different from the mathematics of probability, and we find fuzziness more well suited to solving *imprecise* (i.e., “uncertainty in choosing among alternatives”) problems in the preliminary phase of design. Probability continues to be most appropriate for representing and manipulating the *uncertainty in truth* aspects of design problems. A comparison of probabilistic and fuzzy methods in design will be the subject of a later publication. Many design problems will require both methods.



### 3.1 Representation and Interpretation of Imprecision

A simple range might be used to represent the imprecision for a parameter. This is the technique used in interval analysis [27]. Instead of a range, we represent the imprecise parameter by a range and a preference function to describe the desirability of using that particular value within the range. This preference function is similar to the notion of a *fuzzy set*, or more specifically a fuzzy number which is restricted to the set of real numbers.

A *fuzzy set* (as developed by Zadeh [38]) is a set with boundaries which are not sharply defined. Membership in the set is not the customary 0 or 1, but can be described by a continuum of grades of membership. In the approach described here we use preference values, analogous to membership, to represent imprecision or approximation of engineering design parameters. For example, a designer may want to represent a dimension of “about 25 cm”. He or she would do so by specifying a preference function to represent that approximate parameter.

The first step is to decide the range of values that the parameter may assume. Values less than the low end of the range, and greater than the high end of the range will have membership of zero (0) in the fuzzy representation. For example, there may be a restriction on the dimension to be being greater than 20 cm, and the designer may wish to keep it shorter than 30 cm. The value, or values, that the designer feels the greatest confidence in using, or desire to use, are assigned a preference of one (1). Certainly 25 cm will have a preference of 1 (one) in the fuzzy set: “about 25 cm”, and values away from 25 will have lower preference, as shown in Figure 1.1. Preference is assigned depending on the designer’s desires to use those parameter values. The more confident, or the more the designer desires to use an input value, the higher its preference in the parameter’s set. The resulting function of this process is a quantification of design preference, and not the customary notion of membership in a symbolically labeled fuzzy set, which usually denotes vagueness in meaning. In this way parameters whose values are not known precisely can be represented (and manipulated), and the designer’s experience and judgement can be represented and incorporated into the design evaluation.

Therefore we interpret imprecision as representing the designer’s desire to use a particular value for a design parameter. Naturally these desires may change as the design proceeds, and this is easily accomplished using fuzzy sets. This evolution of knowledge, preference, and emphasis is a common element of the design process, and the technique reported here permits their representation and manipulation.

In the example given above, Figure 1.1, the input preference function depends solely on the subjectivity of the designer. Preference functions need not

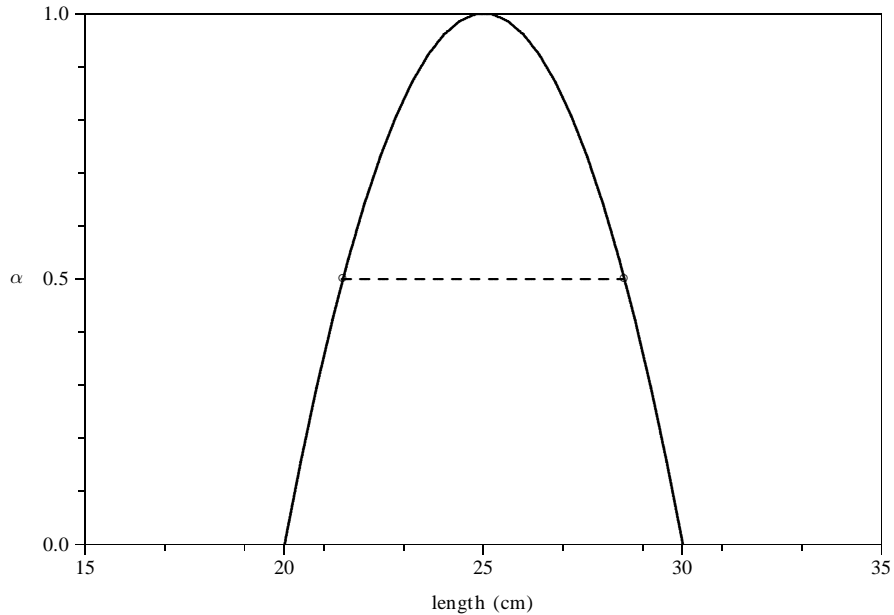

Figure 1.1 Imprecise Representation of “About 25 cm”,  $\alpha$ -cut at 0.5.

always be dependent in this way, engineering data may also be used in certain situations. For example, a variety of materials might be used, and the preference of the designer is to minimize cost, solubility, or some other measurable material property, (or any combination of these). If the cost or other material data are available, the preference function can be constructed by normalizing the data between zero and one, and interpolating a curve between the data points (a method for handling discrete data is presented in [35]). Figure 1.2 is an example preference function constructed from the cost data for certain steel alloys, where the designer has specified a preference of minimum cost.

The *desirability* interpretation, as discussed above, applies to input DPs (those parameters whose value the designer is free to choose). Target values for Performance Parameters are specified by Functional Requirements, not directly by the designer’s desires. Performance Parameters, resulting from calculations with imprecise input Design Parameters (using the authors’ implementation of the Fuzzy Weighted Average algorithm [16] described below), will also be represented by fuzzy preference functions. These output preference functions also represent the designer’s desires, but in a slightly different way from the inputs. The output parameter value with a preference of 1 (one) corresponds to the input values with preference of 1. This is a natural consequence of calculations using the fuzzy calculus [17, 23, 43]. This implies that

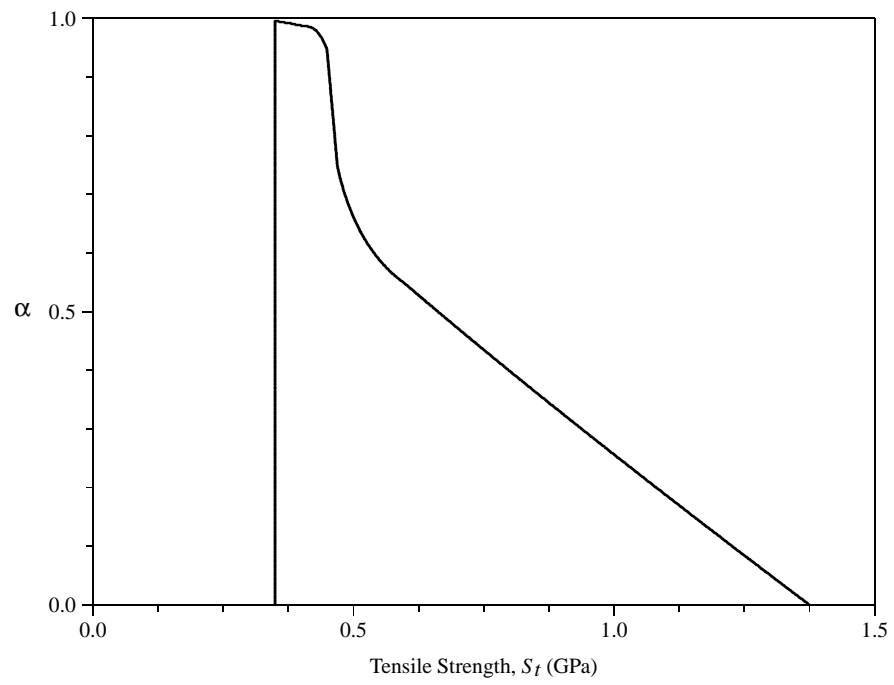

Figure 1.2 Preference Function: Steel Alloy Data

if the designer's desires are met (inputs with preference of 1), then the performance will be the output value with preference of 1. Correspondingly, if the performance parameter output value with preference of 1 satisfies the Functional Requirement(s), then the designer can use the input Design Parameter values with preference of 1. If it is required to use an off-peak value for the performance (to satisfy a Functional Requirement), then either the designer's desires must be adjusted, or input values other than the most desirable must be used. This will be discussed in detail below.

### 3.2 Existing Techniques

There exists a variety of means by which imprecise parameters can be represented and manipulated in engineering design calculations. The most basic approach is to choose single (crisp, non-fuzzy) values for each of the parameters, substitute these into the governing equations, and record the crisp single-valued output. This method benefits from simplicity, but suffers from the time required to "explore" any real design space.

Optimization schemes potentially provide a means for handling imprecise parameters. These methods include direct search methods such as Simplex and three-point equal-interval search, gradient methods such as Newton's and the Conjugate Gradient search [30]. However, conventional optimization methods require precise representations and analyses, and are therefore most useful in the latter stages of design. A. Diaz [13, 14] is developing an optimization technique using imprecise (fuzzy) constraints. This method will be useful for solving imprecise optimization problems, but will not provide as much information on the performance of a design operating over a range of design parameters as the method reported here.

Interval analysis [27] is another method for carrying out computations with imprecise parameters. In this technique an interval (a range of numbers represented by its boundaries) is used to represent a DP in the design calculations. The output (PP) is similarly represented by the two numbers at the end points of an interval. This method has some similarity to the method developed by the authors in that it indicates ranges of possible values for inputs and outputs. Interval analysis, however, provides no information on the performance of a design *within* the interval. All that can be said, when interpreting a Performance Parameter output, is that the design will perform somewhere between the boundaries of the interval. Furthermore, the input values which contributed to any one particular value of the output cannot be directly determined (except at the boundaries). As the number of intervals used to represent DPs increases (e.g. a succession of decreasing interval sizes may be used to cause a PP to approach a desired value), interval analysis approaches the method reported here.

G. Taguchi [10, 32] has developed a technique for evaluating the “quality” of a design based on his loss function. This function is essentially a preference function for a fuzzy representation.<sup>3</sup> Taguchi does not apply the mathematics of fuzzy sets to the evaluation or comparison of designs. Instead, his method employs the principles of “experimental design” which “explores” the design space one crisp design parameter value at a time. Taguchi suggests that the Parameter Design phase will have the most impact on quality. In this phase the values for DPs can be selected to create a design that will be as insensitive as possible to manufacturing errors, environmental conditions, variability in use, etc. The design technique presented here will be a useful extension to Taguchi’s method in the Parameter Design phase (by permitting a more thorough evaluation of the performance parameters over ranges of the design parameters), as well as performing its intended purpose in the preliminary design phase.

Sensitivity analysis permits the evaluation of the rate of change of an output PP as input DPs change. This relies on the evaluation of partial derivatives or Lagrange multipliers of system equations.<sup>4</sup> Sensitivity analysis is a powerful design tool, but provides information only at a single operating point each time it is evaluated, and will provide no information when only discrete values of input design parameters are available. Furthermore, the change in desirability of inputs and outputs is not included in the calculation. For example: one input may have a narrow range of acceptable values, and a different input may have a much wider range of desirability. Even if the numerical sensitivity of one output is the same with respect to these 2 inputs, different design decisions should be reached regarding the effect of altering them. When a preference function is used instead of a range (to represent the designer’s desires) even more information in the form of the rate of change of desirability of an output with respect to an input’s desirability can be found. We introduce the  $\gamma$ -level measure later to evaluate this effect. Sensitivity analysis, as it is usually applied, does not include the effects of imprecision, or the designer’s desires.

If a multi-valued logic form of probability analysis is used (instead of the more common event-frequency form), imprecision of input DPs may be represented, and imprecise output PPs can be calculated [5, 11, 22, 31]. However, the calculus of probabilities does not permit the relationships between inputs and outputs to be found. If, for example, a probability calculation shows that the desired performance has a low likelihood, determining which DPs to change, and how to change them is not possible from the probability calculations alone. Only the expectation of the outputs is available. Furthermore,

---

<sup>3</sup>See particularly the Quadratic Loss Function shown in Figure 3 of [10].

<sup>4</sup>Reference [30] pages 168 and 609.

some probability calculations (on imprecise parameters rather than uncertain parameters) can produce unexpected results.<sup>5</sup>

The method presented here, based on a fuzzy representation of imprecision, extends the capabilities of the methods described above by permitting: representation of imprecise input Design Parameters; calculation of resulting Performance Parameters (with corresponding levels of imprecision); evaluation of Design Parameters to attain a desired Performance Parameter; and estimates the relationship between DPs and PPs over a wide range of values.

#### 4. Approach

As described in the previous section, we have adopted the fuzzy calculus as a mathematical representation of imprecision in engineering design. The arithmetic and calculus of fuzzy sets and fuzzy numbers provides us with a method for manipulating these imprecise representations.

Fuzzy numbers and their associated arithmetic and calculus are the subject of many publications and several textbooks [17, 23, 43] and will not be presented here.

In brief, fuzzy arithmetic is based on Zadeh's extension principle [40]. Kaufman and Gupta [23] have shown analytically that this is equivalent to an  $\alpha$ -cut form of the mathematics [23]. The  $\alpha$ -cut form of some simple mathematical operations are shown in the Appendix.<sup>6</sup> Finally, a discrete version of the mathematics utilizing interval analysis at discrete  $\alpha$ -cuts has been developed by Wong and Dong [16] utilizing their Fuzzy Weighted Average (FWA) algorithm.<sup>7</sup>

Figure 1.1 shows an  $\alpha$ -cut at preference 0.5. The discrete FWA algorithm treats each  $\alpha$ -cut as an interval, and performs interval analysis to calculate each output preference interval [16]. The important addition to interval analysis, however, is the preference value associated with each value in the fuzzy number. It can be seen that as successively smaller intervals are used in a calculation, interval analysis approaches fuzzy set mathematics.

One important ramification of fuzzy mathematics is that once a forward calculation is made (operating on inputs to determine an output fuzzy function),

<sup>5</sup>For example:  $y = mx + b$  where  $m$ ,  $x$ , and  $b$  have probabilistic representations centered at a value of 3.0, produces an output with a peak likelihood at  $y = 11.6$  rather than the value 12. A detailed comparison of probability analysis and the authors' technique is the subject of a later publication.

<sup>6</sup>A discussion of the Extension principle and  $\alpha$ -cuts can be found in Dubois and Prade [17], Chapter 2, pages 36-67 and page 19 respectively.

<sup>7</sup>The analytical method of calculating a fuzzy output from imprecise inputs is infeasible for computer-assisted design applications. Wong and Dong's FWA algorithm is used here, in a computationally efficient implementation developed by the authors. This algorithm has computational complexity of order:  $M \cdot 2^{(N-1)} \cdot \kappa$ , where  $M$  = the number of  $\alpha$ -cuts for each parameter,  $N$  = the number of parameters, and  $\kappa$  = the number of (combinatorial interval-analysis) operations for one  $\alpha$ -cut. Example fuzzy-set calculations are shown in the Appendix.

then *backward* calculations can be obtained with no further computation. The peak of a fuzzy output corresponds to the peak value for each of the inputs, off-peak output values correspond to off-peak inputs with the same preference value. For example, if a designer performed a fuzzy calculation, and the output parameter's peak value (preference of one (1)) was not acceptable, then he or she could select a different output value and determine its preference value. The designer then knows that the inputs required to produce that output have the same preference or less. If the designer wishes to use an output parameter value with preference of 0.7, then he or she knows that at least one input must also have a preference of 0.7 or less, the other inputs having preference distributed about 0.7. In this way the relationship between inputs and outputs is readily observed. The backward path through the calculations is a natural consequence of the fuzzy arithmetic implementation developed by the authors, and requires no further calculations once the forward path has been calculated.

#### **4.1 Preference Function Shapes for Design Parameters**

A simple form of the preference functions described above is triangular (single most desired/confident value with linear interpolation to the zero confidence values) or trapezoidal (interval of most desired/confident values at preference of one (1)). For preliminary design, the experiments conducted to-date indicate that these two classes of preference function shape will adequately approximate input DPs imprecise representation. These types of functions also satisfy the normality and convexity conditions required of fuzzy numbers. If it becomes necessary to use higher-order functions, they can be included without modification to the technique or implementation described here. For example, to bias a preference around the most preferred input, a quadratic function can be used. Likewise, to bias the preference in the opposite sense, an inverse quadratic function, which approaches a Dirac delta function in the extreme case, may be applicable. Furthermore, if multiple peaks are found to be required, then the convexity condition may be relaxed slightly such that the preference functions are treated as multiple locally convex functions.

Besides triangular and trapezoidal functions, preference functions can be constructed exactly from engineering data (Figure 1.2), if the data and interpretation are available. For an incomplete set of data, a preference function may be approximated by curve fitting (analogous to the construction of subjective probability density functions) to certain points of preference in a design parameter's input range.

For triangular inputs, the outputs of design performance analysis functions may not always be linear functions, as shown by the example in the Appendix. A fuzzy multiplication with triangular input functions does not result in a

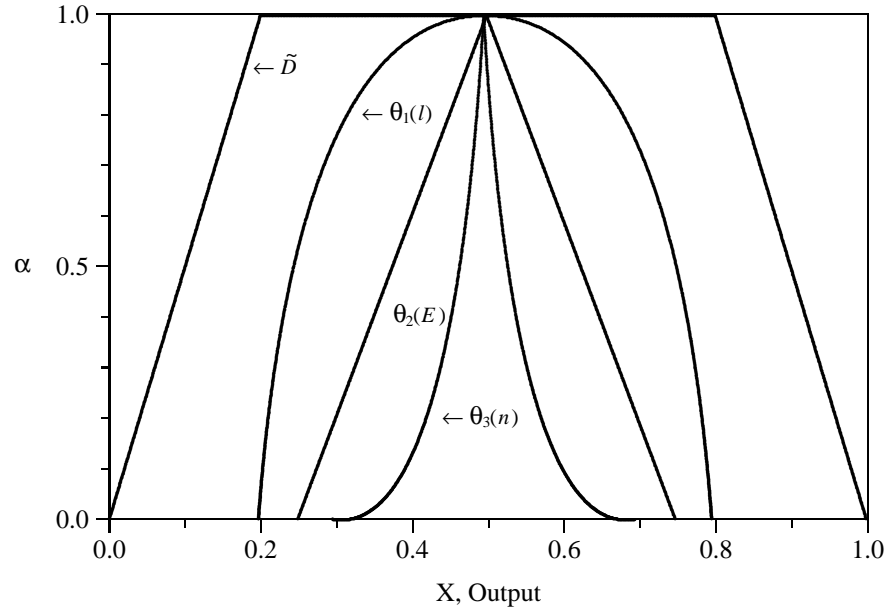

Figure 1.3 Measure of Fuzziness Example

triangular output function, but instead two combined functions raised to the one-half power. Addition and subtraction will preserve the shape of the input function, but the multiplication and division operators both produce nonlinear results. In general, curves of different shape than the input may be expected for the results of fuzzy engineering design computations, however, the result of a fuzzy calculation may be interpreted as previously discussed, whatever its shape.

## 4.2 A Design Measure

In any design calculation, some input parameters are very strongly coupled to the outputs, and others are nearly independent. A means of determining the relative coupling between imprecise (fuzzy) inputs and outputs can be used to determine which parameters the designer can change and produce little effect on the performance, and which parameters will have the most profound effect on the output. A new measure developed for this purpose, called the  $\gamma$ -level measure, is presented below, along with a well known Measure of Fuzziness.

**4.2.1 Measure of Fuzziness.** The *Measure of Fuzziness* expresses “the difficulty of deciding which elements belong and which do not belong to a given fuzzy set” [17]. The following entropy function satisfies the conditions



required of a measure of fuzziness [12]:

$$d(\tilde{C}) = K \sum_{i=1}^{|\tilde{X}|} \Psi(\alpha_{\tilde{C}}(x_i)), \quad (1.1)$$

where:

$$\Psi(y) = -y \ln(y) - (1 - y) \ln(1 - y),$$

$\alpha_{\tilde{C}}$  is the membership function of the fuzzy set  $\tilde{C}$ ,  $|\tilde{X}|$  is the length of the discretized support (region of non-zero membership) of  $\tilde{C}$ , and  $K$  is an integer.

Unfortunately the entropy function as defined in Equation 1.1 measures values centered on  $\alpha_{\tilde{C}} = \frac{1}{2}$ . A membership value of one-half has the highest degree of “difficulty of deciding” whether it is a member of the set or not. Memberships close to one (1) are closer to being in the set, memberships close to zero (0) are closer to being out of the set. Thus this measure indicates how much of the membership function is close to one-half. In design, the engineer needs a measure of the values centered on  $\alpha_{\tilde{C}} = 1$ , indicating the “spread” of the preference function (near 1), not the steepness of the bounding curves (for membership functions). Figure 1.3 illustrates the difference. The *Measure of Fuzziness* will have the same value for membership functions  $\tilde{C}_1$  and  $\tilde{C}_2$  since these two curves have the same amount of  $x$  near  $\alpha = 0.5$ , however,  $\tilde{C}_1$  has much greater imprecision (in the preference function interpretation) than  $\tilde{C}_2$  (a much larger amount of  $x$  near  $\alpha = 1.0$ ). To avoid this difficulty, a new measure has been developed by the authors.

**4.2.2 The  $\gamma$ -Level Measure.** We have developed a new measure which we will call the  $\gamma$ -level measure. We define this measure in the following manner:

$$D(\tilde{C}) = \sum_{i=1}^{|\tilde{X}|} (e^{\beta(x_i)} - 1)^m, \quad (1.2)$$

where

$$\beta(x_i) = \begin{cases} \frac{\alpha_{\tilde{C}}(x_i)}{\gamma} & \text{if } \alpha_{\tilde{C}} \leq \gamma \\ \frac{2\gamma - \alpha_{\tilde{C}}(x_i)}{\gamma} & \text{if } \alpha_{\tilde{C}} \geq \gamma, \end{cases}$$

$$0 < \gamma \leq 1,$$

and  $m$  is an integer such that as  $m$  increases, the measure becomes more concentrated for values about  $\alpha_{\tilde{C}} = \gamma$ . The value of  $\gamma$  may be set so that  $D(\tilde{C})$  measures values in the support centered about it. For  $\gamma = \frac{1}{2}$  the  $\gamma$ -level measure satisfies the conditions for the *Measure of Fuzziness* [12]. We will use  $\gamma = 1.0$  and  $m = 1.0$  in Equation 1.2.

An outline of the process by which this  $\gamma$ -level measure can be used as a qualitative measure of the relationship between input design parameters and

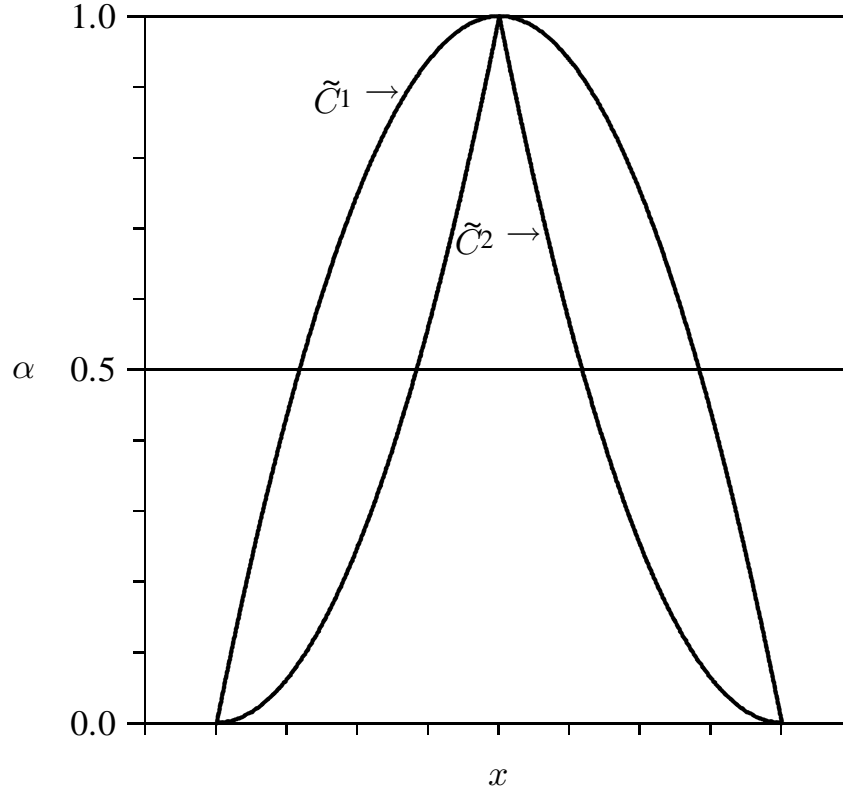

Figure 1.4  $\gamma$ -Level Measure Application

output performance parameters is shown below. Let  $\tilde{C}_1, \dots, \tilde{C}_N$  be  $N$  input, imprecise inputs (Design Parameters), and let  $\tilde{D}$  be the output (Performance Parameter) of the computation  $y = f(x_1, \dots, x_N)$ .

1. Determine  $\tilde{D}$  using the FWA algorithm [16].
2. Let  $\lambda_1$  and  $\lambda_2$  be equal to the two  $x$  values for which  $\alpha_{\tilde{D}} = \text{minimum}$  on both the left and right extremes of  $\tilde{D}$ .  $\Lambda = [\lambda_1, \lambda_2]$  makes up an interval of the support of  $\tilde{D}$ .
3. Discretize the interval  $\Lambda$  into  $n$  equally spaced steps, such that  $|X| = n$  in Equation 1.2.
4. For each input parameter,  $\tilde{C}_i$ ,  $i = 1, \dots, N$ , set all other  $\tilde{C}_j, i \neq j$ , to their nominal crisp value (where  $\alpha_{\tilde{C}} = 1$ ). For  $i = 1, \dots, N$ , use the FWA to calculate the output,  $\Theta_i$ , where the  $i^{\text{th}}$  fuzzy input remains fuzzy in the calculation, and all others are made crisp as above.

5. Calculate the  $\gamma$ -level measure ( $\gamma = 1$ ) for  $\tilde{D}$  and all  $\Theta_i$ .
6. Normalize the  $D(\Theta_i)$ 's with respect to  $D(\tilde{D})$ . The result is an ordering of the inputs according to importance (relative measure), giving a qualitative relationship of inputs to the output.

For the engineer who utilizes fuzzy preference functions in the description of design and performance parameters, this new measure provides the ability to determine some information on the coupling between the inputs and outputs of design calculations. The measure can also be used to determine which parameters the designer can change and produce little or no effect on the performance, and which parameters will alter the output the most. Those parameters with small influence may be fixed to the most-desired value by the engineer, resulting in a simplification of the design problem. The coupling information not only includes the rate of change of an output with respect to an input (over the range of acceptable values), but also includes the change in desirability of the parameters. If a small change of an input produces a large change in an output, but a small change in the desirability of the output, the  $\gamma$ -level measure will be small (even though the *sensitivity* of the output to that input is large). Similarly, if a large change of an input produces a small change in an output, but a large change in the desirability of the output, the  $\gamma$ -level measure will be large.

Figure 1.4 illustrates an example application of the  $\gamma$ -level measure.  $\tilde{D}$  is the output fuzzy set of some performance parameter which is functionally related through a PPE to three imprecise input parameters  $E$ ,  $n$ , and  $l$ . The  $\Theta_i$  sets make up fuzzy outputs for only one fuzzy input parameter (and the other inputs held at their crisp value). After applying the  $\gamma$ -level measure to each of these output sets, the results may be ordered from largest to smallest. In this case, the ordering consists of the following:  $D(\tilde{D})$ ,  $D(\Theta_1)$ ,  $D(\Theta_2)$ ,  $D(\Theta_3)$ . Normalizing the output measures  $D(\Theta_i)$  with respect to  $D(\tilde{D})$  shows that  $D(\Theta_1)$  is much greater than for  $D(\Theta_3)$ . The parameter for  $\Theta_3$  ( $n$ ) contributes very little to the preliminary design analysis when compared to the parameter for  $\Theta_1$  ( $l$ ). Thus, the input parameter  $n$  might be fixed to its crisp value (where its preference equals one (1)).

## 5. Example

A simple mechanical design example using the approach described in the previous section is presented here. The problem is to design a mechanical structure, attached to a wall at one end, which will support an overhanging vertical point load. Constraints on the problem include: the distance the load is from the wall; the total width of the supporting structure; and the materials used for the structural elements. One possible configuration, shown in

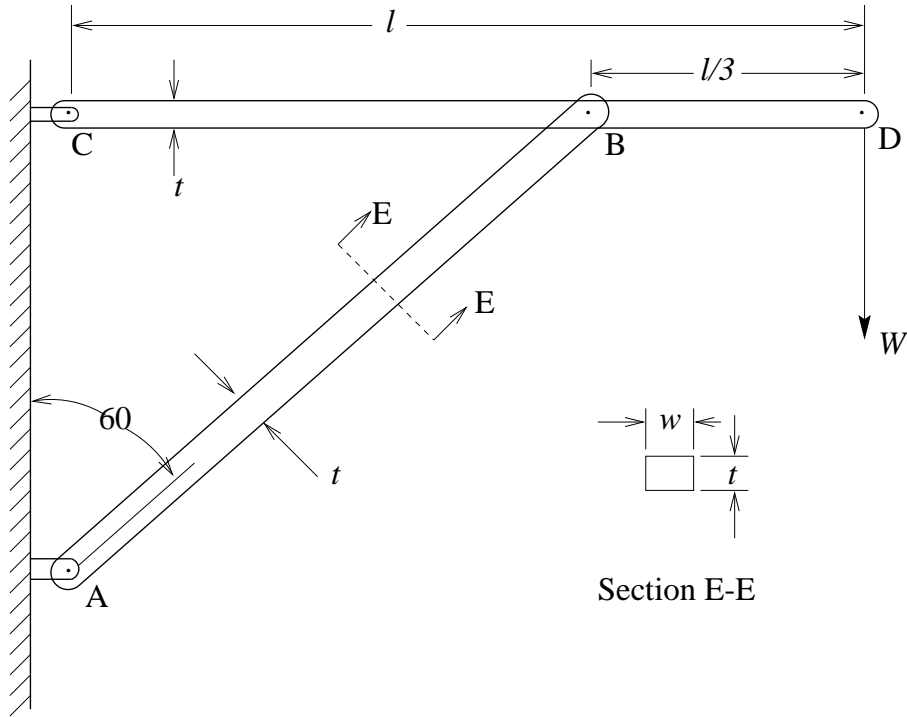

Figure 1.5 Design Problem: Frame Configuration

Figure 1.5, consists of a two-member frame, where the compression member ( $AB$ ) is attached to the wall at an angle of sixty degrees ( $60^\circ$ ) and both members have rectangular cross-sections. The global design objective is to avoid failure in either component of the frame. Performance expressions may be obtained for the two Functional Requirements by considering beam bending theory<sup>8</sup> for the horizontal member ( $CD$ ), and buckling for the compression member ( $AB$ ). The resulting Performance Parameters for the design are the maximum bending stress  $\sigma$  in  $CD$  and the column load  $F_B$  on  $AB$ :

$$\sigma = \frac{2l(W + \frac{W_{CD}}{6})}{w_{CD}t^2}, \quad (1.3)$$

$$F_B = \sqrt{\left\{ \frac{9}{2\sqrt{3}} \left( W + \frac{W_{CD}}{2} + \frac{W_{AB}}{3} \right) \right\}^2 + \left\{ \frac{3}{2} \left( W + \frac{W_{CD}}{2} \right) \right\}^2}. \quad (1.4)$$

<sup>8</sup>Shear stress in the horizontal member and elastic deformation of the entire frame do not contribute significantly to the problem.

The design parameters for this example are as follows: the applied load  $W$ ; the length of member  $CD$   $l$ ; the width of the compression member  $w_{AB}$ ; and the thickness  $t$ . If a different material is used, or a range of material properties are available,  $E$  and  $\rho$  may also be included as imprecise DPs. The relationships for the weight of the two members, and a constraint on width ( $w$ ) are:

$$W_{CD} = \rho g w_{CD} t l, \quad (1.5)$$

$$W_{AB} = \rho g w_{AB} t \left( \frac{4\sqrt{3}l}{9} \right), \quad (1.6)$$

$$w_{CD} = w_{AB} - 2.5 \text{ cm.} \quad (1.7)$$

## 5.1 Performance Specifications

In this design,  $\sigma$  must be less than the maximum bending stress before yield. This example assumes that the material has been specified to be steel. Thus, the functional requirement for maximum bending stress is:

$$\sigma \leq \sigma^r = 225 \text{ MPa,}$$

where the superscript  $r$  denotes “requirement.”

For simplicity, we will only consider the Functional Requirement on bending stress  $\sigma$  in member  $CD$  in the example shown here. Future publications will demonstrate the technique with examples containing more realistic design complexities, and comparisons of design alternatives. In the actual design of a frame, such as the one used in this example, buckling of member  $AB$  would need to be included in the analysis.

## 5.2 Input Design Parameters

The designer specifies the input parameters as preference functions according to the approach outlined previously. Here the parameters that need to be selected as part of the design process are:  $W$ ,  $w_{AB}$ ,  $l$ , and  $t$ . In this example, the subjective knowledge, experience, and desires of the engineer are used to imprecisely determine these input parameters. For example, the applied vertical load  $W$  is constrained by a maximum load that a proposed configuration is expected to withstand without failure. There also exists some latitude (due to other design considerations) by which this design load may be decreased such that the design is still *satisfactory*, but less *desirable* due to the decrease. Thus, the input parameter  $W$  is imprecisely defined in a range of possible values where the desirability decreases from the maximum value in the range to the

Figure 1.6 Input Parameter:  $W$ 

Table 1.1 Example Problem: Fuzzy Design Parameter Data.

DPs (units)	$\alpha = 0$	$\alpha = 1$	$\alpha = 0$
$W$ (kN)	15.0	20.0	20.0
$w_{AB}$ (m)	0.04	0.07	0.13
$l$ (m)	3.0	4.0	4.0
$t$ (m)	0.04	0.06	0.10

minimum value shown in Figure 1.6. For this design problem, the maximum design load is 20 kN, which corresponds to the upper endpoint of the range.  $W$  may not be less than 15 kN, corresponding to the lower endpoint.

The remaining design parameters may be specified in a similar manner. Because each input set for this problem is in the form of a triangular function (naturally more complex functions could have been used), the fuzzy DPs can be represented by three-values: left-extreme value for preference of zero, peak value for preference of one, and right-extreme value for preference of zero. Table 1.1 provides the necessary data for constructing the preference functions for the entire set of design parameters, and Table 1.2 lists other constant data used in this example design problem.

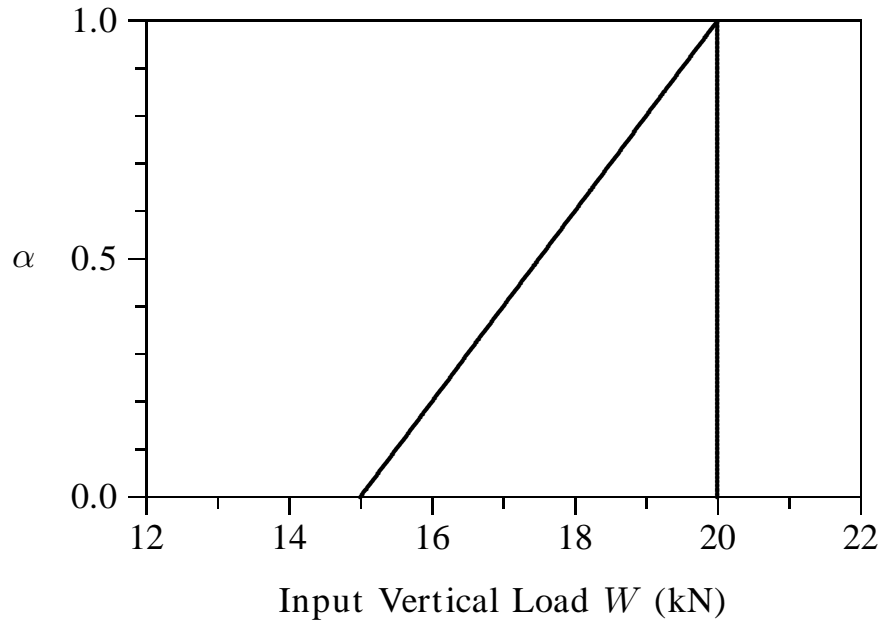
Table 1.2 Design Example: “Constant” Data.

Constant (units)	Value
$E$ (GPa)	207.0
$\rho$ (kg/m <sup>3</sup> )	7830.0
$g$ (m/sec <sup>2</sup> )	9.81

### 5.3 Output Performance Parameters

The fuzzy output for the performance parameter  $\sigma$  may be obtained by use of Equation 1.3 and the application of the FWA algorithm described earlier. The results are shown in Figure 1.7.

After the calculations have been performed to produce the output, the next step is to compare the output set with the performance criterion. Figure 1.7 shows the imprecise performance parameter results for the maximum bending stress of member  $CD$  (Equation 1.3). The output at the peak of  $\tilde{\sigma}_{(at\ \alpha=1)}$  is equal to 994 MPa. This peak output does not satisfy the functional requirement  $\sigma^r = 225$  MPa. To satisfy the requirement  $\sigma^r$ , the input parameters must deviate from the peak (most desired) values. At least one design parameter must decrease in preference, to the left of the peak, by between 0.5 and 0.6 ( $\tilde{\sigma}_{(at\ \alpha=0.5)} = 259$  MPa and  $\tilde{\sigma}_{(at\ \alpha=0.4)} = 206$  MPa), in order to meet the requirement on  $\sigma$ . (If a factor of safety is desired, a further decrease in preference will be required.)

The backward path of the imprecise calculation may be applied at this point to determine the effect of changing the preference of any one input design parameter. Data from the solution for  $\tilde{\sigma}$  shows that the input parameters of  $W$  and  $l$  could be decreased to the left of their peak values (at  $\alpha = 1$ ) so that  $\sigma$  will meet its Functional Requirement, whereas the inputs  $w_{AB}$  and  $t$  must be decreased to the right of their peak values. This result cannot easily be obtained from inspection of the governing equation since  $w_{AB}$  and  $t$  appear in the denominator *and* the numerator of Equation 1.3 when combined with Equation 1.6. While this same result could be obtained through calculation of partial derivatives of the output with respect to each of the inputs, it was instead found by use of stored values calculated during the solution of the (imprecise) performance parameter by use of the authors’ implementation of the FWA algorithm. No additional calculations were required. These results show that  $\sigma^r$  may be satisfied by the frame configuration, but only with a large change in preference of the DPs from the most desired input peak values. If other PPs were part of this design analysis (in addition to  $\sigma$ ), care must be taken when adjusting the DPs (which are coupled to  $\sigma$ ) to obtain acceptable performance values in those other PPs. A small adjustment of one DP to obtain

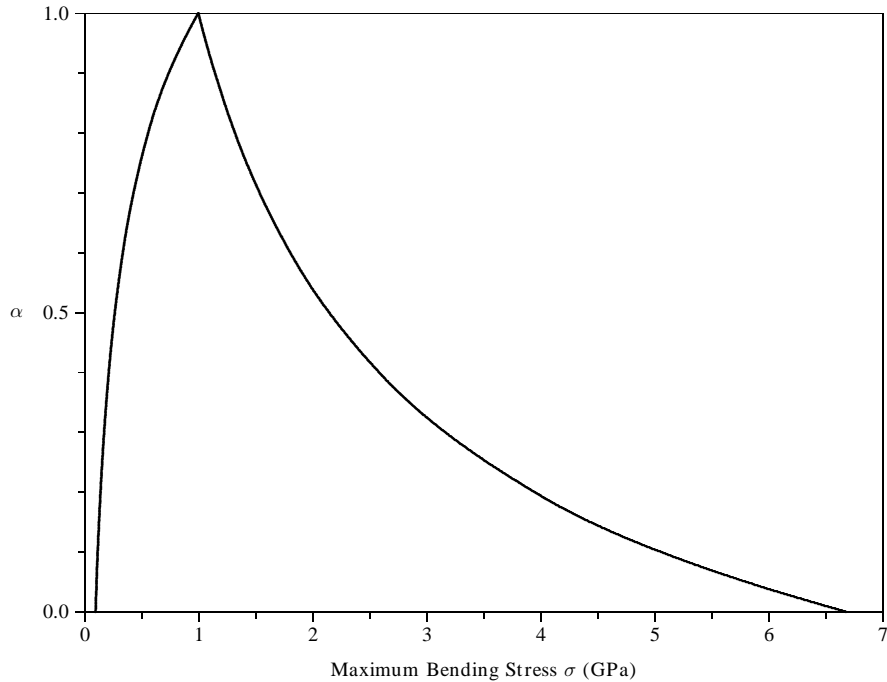

Figure 1.7 Output Parameter: Maximum Bending Stress  $\sigma$

a satisfactory performance value for one PP may adversely affect a different PP. The  $\gamma$ -level measure may be used to determine the magnitude of the coupling between parameters, and permit the designer to minimize the adverse effect of DP adjustment.

#### 5.4 Applying the $\gamma$ -Level Measure

The  $\gamma$ -level measure, as described earlier, may be used to provide the engineer with qualitative information on the relationship between input parameters in the design. When a design parameter has the greatest qualitative importance for a given performance parameter, the numerical measure produces a normalized value of one (1). As the measure decreases in value, the corresponding input has little effect in determining the performance, meaning that even a large change in the design parameter (decrease in preference/desirability) produces a small change in output. The output of the  $\gamma$ -level measure is loosely analogous to sensitivity, but applies to the imprecise parameters, and represents the entire range of the parameters, not a single operating point. Moreover, this sensitivity is weighted by the designer's desires, as identified in the input parameters' preference functions.



Table 1.3  $\gamma$ -Level Measure Results: Frame Configuration.

<i>Performance Parameter: <math>\sigma</math></i>	
DPs	$\gamma$ -Level Measure
$W$	0.129
$w_{AB}$	1.000
$l$	0.129
$t$	0.910

Table 1.3 lists that  $\gamma$ -level results for the frame configuration. Analyzing the  $\gamma$ -level measures for  $\sigma$ , the input parameters  $t$  and  $w_{AB}$  are obviously the most important parameters which must be changed from their peak preference values in order to meet the Functional Requirement.  $W$  and  $l$  contribute very little when compared with  $t$  and  $w_{AB}$ . Thus,  $W$  and  $l$  may be set to their representative or desired values, resulting in a simplification of the frame design.

When more than one performance parameter is used to describe a design, and when there exist imprecise performance specifications, the  $\gamma$ -level measure may also be used to determine the coupling of the design parameters, as well as the importance of the DPs for maximization or minimization. A subsequent publication [34] demonstrates the use of the  $\gamma$ -level measure for these purposes.

### 5.5 Discussion

This example shows how imprecision in the design parameters can be handled, how the designer can move forward and backward through the design calculations to determine interactions of the DPs for the performance parameters, and how the  $\gamma$ -level measure may be used to determine information relative to the importance of the design parameters. Conclusions may be drawn from the results as to the ability of the configuration to satisfactorily meet the performance criteria (including consideration of the designer’s desires), and if the configuration should be carried on to the next stage in the design process.

This design problem has been a simple example, with none of the complications that normally beset engineering designers, such as alternative configurations or technologies to compare; simultaneous analysis of multiple performance parameters; poor knowledge of the relationships between functional requirements and design parameters; and intangible requirements and specifications, such as aesthetics. The example does, however, demonstrate an enhanced capability for the designer to determine acceptable DP values, or ranges, simply and quickly by use of imprecise computations. Examples, which are considerably more complex in terms of comparing different design

alternatives and in terms of including uncertainty effects, in addition to imprecision, will be presented in later publications.

## 6. Conclusions

One of the goals of the research reported here is to increase the amount of information available to engineering designers regarding the performance of design alternatives, over that available with conventional design analyses. The effect will be greater, the earlier in the design process the information is made available. Ultimately the most important (and costly) decisions in the design cycle are made in the very early stages. Engineering designs are typically represented imprecisely at the early, conceptual (preliminary) stage of design. Computational tools for this area of the design process are rare, largely because of the scarcity of techniques capable of handling imprecise data. One of the central hypotheses of the research reported here is that representing and manipulating imprecise descriptions of design artifacts during the preliminary phase (and hence increasing the information available to the designer) will enable design decisions to be made with greater confidence and reduced risk, and that this will ultimately result in better designs.

The technique and implementation reported here represents a new application (to the engineering design process) of a powerful approach to represent and manipulate imprecise engineering design data. The example shown here demonstrates that it can be applied to engineering design problems, and provide the ability to perform design calculations on a variety of imprecise parameters. The (correspondingly) imprecise-calculation results provide more information to the designer than conventional single-valued design analyses. The technique used is a modified implementation of the Fuzzy Weighted Average operating on fuzzy representations of design parameters. Preference functions are used here to represent the designer's desire to use particular values for these parameters.

Additional useful information that this method can provide, through the use of the  $\gamma$ -level measure, is the coupling between imprecise representations of design parameters (inputs) and the performance parameter results. This coupling information can be used to focus the engineer's resources on those aspects of the design problem with the largest effect on the resulting performance.

Subsequent publications will compare this method with probability analysis, as well as develop additional examples.

## 7. Acknowledgements

This material is based upon work supported, in part, by: The National Science Foundation under a Presidential Young Investigator Award, Grant No. DMC-

8552695; The Caltech Program in Advanced Technologies, sponsored by Aerojet General, General Motors, and TRW; and an IBM Faculty Development Award. Mr. Wood is currently an AT&T-Bell Laboratories Ph.D. scholar, sponsored by the AT&T foundation. Any opinions, findings, conclusions or recommendations expressed in this publication are those of the authors and do not necessarily reflect the views of the sponsors.

## A Appendix: Fuzzy Arithmetic

### A.1 Operations for Fuzzy Numbers

Zadeh [40] introduced the extension principle as one of the fundamental ideas of fuzzy set theory. Using this idea, classical mathematics may be extended to the fuzzy domain. Specifically, let the fuzzy sets (or fuzzy numbers)  $\tilde{C}_1, \tilde{C}_2, \dots, \tilde{C}_N$  be defined in the universes  $X_1, X_2, \dots, X_N$ , respectively. The mapping from  $X_1 \times \dots \times X_N$  to a universe  $Y$  may be defined as a function  $f$  such that  $y = f(x_1, \dots, x_N)$ . The extension principle then gives that a fuzzy set (or number)  $\tilde{D}$  on  $Y$  may be induced from  $\tilde{C}_1, \tilde{C}_2, \dots, \tilde{C}_N$  through  $f$  such that the resulting membership function is:

$$\mu_{\tilde{D}}(y) = \sup_{x_1, \dots, x_N} \min(\mu_{\tilde{C}_1}, \dots, \mu_{\tilde{C}_N})$$

where  $y = f(x_1, \dots, x_N)$ . The ordinary binary operations may then become extended operations in the fuzzy domain (extended addition, extended multiplication, etc.).

Even though the development of these extended operations may be completed rigorously using the extension principle approach, interval operations for  $\alpha$ -level sets will be presented instead, as this method is used in the computer implementation.

**DEFINITIONS.** Some aspects of Fuzzy arithmetic are presented below based on the material in Kaufmann and Gupta [23].

**a.  $\alpha$  - Level-Set** The discussion of a fuzzy number with respect to its membership values leads directly to the idea of defining crisp sets (or intervals of confidence) for each level,  $\alpha$ . Specifically, an  $\alpha$ -level-set,  $C_\alpha$ , is a crisp set taken from the fuzzy set  $\tilde{C}$  such that

$$C_\alpha = \{x | \mu_{\tilde{C}}(x) \geq \alpha\}, \alpha \in [0, 1]. \quad (\text{A.1})$$

**b. Addition and Subtraction** Two fuzzy numbers,  $\tilde{E}$  and  $\tilde{F}$ , may be summed or subtracted level by level ( $\alpha \in [0, 1]$ ) according to the following formulas:<sup>9</sup>

$$\begin{aligned} E_\alpha \oplus F_\alpha &= [e_l^\alpha + f_l^\alpha, e_r^\alpha + f_r^\alpha], \\ E_\alpha \ominus F_\alpha &= [e_l^\alpha - f_r^\alpha, e_r^\alpha - f_l^\alpha] \end{aligned}$$

where

$$E_\alpha = [e_l^\alpha, e_r^\alpha], F_\alpha = [f_l^\alpha, f_r^\alpha].$$

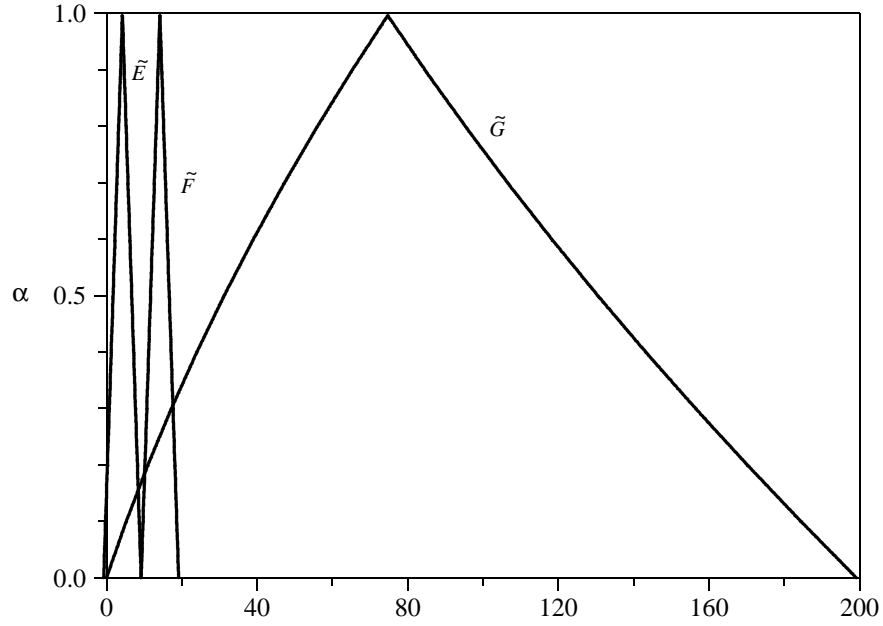

Figure A.1 Multiplication of  $\tilde{E} \times \tilde{F} = \tilde{G}$ .

**c. Multiplication and Division** Similarly, two fuzzy numbers,  $\tilde{E}$  and  $\tilde{F}$ , may be multiplied or divided<sup>9</sup> (considering  $\mathfrak{R}^+$  only here)

$$\begin{aligned} E_\alpha \odot F_\alpha &= [e_l^\alpha \cdot f_l^\alpha, e_r^\alpha \cdot f_r^\alpha], \\ E_\alpha \oslash F_\alpha &= [e_l^\alpha / f_r^\alpha, e_r^\alpha / f_l^\alpha]. \end{aligned}$$

**d. Example of Fuzzy Multiplication** For simplicity, consider the fuzzy numbers,  $\tilde{E}$  and  $\tilde{F}$  as shown in Figure A.1.

The membership functions are given by

$$\begin{aligned} \mu_{\tilde{E}} &= \frac{1}{5}x, \quad 0 \leq x \leq 5, \\ &= -\frac{1}{5}x + 2, \quad 5 \leq x \leq 10, \\ &= 0, \quad \text{otherwise,} \end{aligned} \tag{A.2}$$

$$\mu_{\tilde{F}} = \frac{1}{5}x - 2, \quad 10 \leq x \leq 15,$$

<sup>9</sup>Although nonfuzzy operations are easily extended to their fuzzy counterparts, it must be noted that certain properties of the classical binary operations are lost in the process [23].

$$\begin{aligned}
&= -\frac{1}{5}x + 4, \quad 15 \leq x \leq 20, \\
&= 0, \text{ otherwise.}
\end{aligned} \tag{A.3}$$

In terms of the levels of presumption,  $\alpha$ , Equation A.2 becomes

$$\alpha = \frac{e_l^\alpha}{5} \tag{A.4}$$

and

$$\alpha = -\frac{e_r^\alpha}{5} + 2. \tag{A.5}$$

Similarly, equation A.3 leads to

$$\alpha = \frac{f_l^\alpha}{5} - 2 \tag{A.6}$$

and

$$\alpha = -\frac{f_r^\alpha}{5} + 4. \tag{A.7}$$

Combining the results, we end up with expressions for  $E_\alpha$  and  $F_\alpha$ :

$$E_\alpha = [5\alpha, -5\alpha + 10]$$

and

$$F_\alpha = [5\alpha + 10, -5\alpha + 20].$$

Multiplying leads to

$$\begin{aligned}
G_\alpha &= [(5\alpha)(5\alpha + 10), \\
&\quad (-5\alpha + 10)(-5\alpha + 20)] \\
&= [25\alpha^2 + 50\alpha, 25\alpha^2 - 150\alpha + 200],
\end{aligned} \tag{A.8}$$

where  $G_\alpha = E_\alpha \odot F_\alpha$ . Solving the quadratics on each end of the interval and retaining only two roots for  $\alpha$ , we have that

$$\begin{aligned}
x_l = 25\alpha^2 + 50\alpha &\implies \alpha_l = -1 + \sqrt{\frac{x_l}{25} + 1}, \\
x_r = 25\alpha^2 - 150\alpha + 200 &\implies \alpha_r = 3 - \sqrt{\frac{x_r}{25} + 1},
\end{aligned}$$

where

$$\begin{aligned}
0 &\leq x_l \leq 75, \\
75 &\leq x_r \leq 200.
\end{aligned}$$

## References

- [1] BALDWIN, J. F. A model of fuzzy reasoning and fuzzy logic. Research em/fs10, University of Bristol, Eng. Math. Dept., 1978.
- [2] BALDWIN, J. F., AND GUILD, N. C. F. Feasible algorithms for approximate reasoning using a fuzzy logic. Research em/fs8, University of Bristol, Eng. Math. Dept., 1978.
- [3] BALDWIN, J. F., AND GUILD, N. C. F. A model of multicriteria decision making using fuzzy logic. Research em/fs12, University of Bristol, Eng. Math. Dept., 1978.
- [4] BALDWIN, J. F., AND PILSWORTH, B. W. Axiomatic approach to implication for approximate reasoning using fuzzy logic. Research em/fs6, University of Bristol, Eng. Math. Dept., 1978.
- [5] BECK, J. V., AND ARNOLD, K. J. *Parameter Estimation in Engineering and Science*. John Wiley and Sons, New York, 1977.
- [6] BLOCKLEY, D. I. Predicting the likelihood of structural accidents. In *Proceedings Institute Civil Engineers* (Dec. 1975), pp. 659–668.
- [7] BLOCKLEY, D. I. The role of fuzzy sets in civil engineering. *Fuzzy Sets and Systems* 2 (1979), 267–278.
- [8] BLOCKLEY, D. I. *The Nature of Structural Design and Safety*. Ellis Norwood Limited, Chichester, 1980.
- [9] BROWN, C. B. A fuzzy safety measure. *ASCE Journal of the Engineering Mechanics Division* (Oct. 1980), 855–872.
- [10] BYRNE, D. M., AND TAGUCHI, S. The Taguchi approach to parameter design. In *Quality Congress Transaction – Anaheim* (May 1986), ASQC, pp. 168–177.
- [11] COX, R. T. *The Algebra of Probable Inference*. Johns-Hopkins University Press, Baltimore, MD, 1961.
- [12] DELUCA, A., AND TERMINI, S. A definition of a nonprobabilistic entropy in the setting of fuzzy set theory. *Information and Control* 20 (1972).
- [13] DIAZ, A. R. Fuzzy set based models in design optimization. In *Advances in Design Automation - 1988* (New York, NY, Sept. 1988), S. S. Rao, Ed., vol. DE-14, ASME, pp. 477–485.
- [14] DIAZ, A. R. Modeling of computer-based decisions and optimization in the design process. In *Design Theory '88* (RPI, Troy, NY, June 1988), S. L. Newsome and W. R. Spillers, Eds., NSF, pp. 286–295. 1988 NSF Grantee Workshop on Design Theory and Methodology.
- [15] DIXON, J. R., DUFFEY, M. R., IRANI, R. K., MEUNIER, K. L., AND ORELUP, M. F. A proposed taxonomy of mechanical design problems.

- In *Computers in Engineering 1988* (New York, NY, June 1988), V. A. Tipnis and E. M. Patton, Eds., ASME, pp. 41–46.
- [16] DONG, W. M., AND WONG, F. S. Fuzzy weighted averages and implementation of the extension principle. *Fuzzy Sets and Systems* 21, 2 (Feb. 1987), 183–199.
- [17] DUBOIS, D., AND PRADE, H. *Fuzzy Sets and Systems: Theory and Applications*. Academic Press, New York, 1980.
- [18] FUTURA, H., ET AL. Optimum aseismic design using fuzzy sets and empirical connectives. Communication with Dr. Yao Purdue, 1986.
- [19] FUTURA, H., AND NARUHITO, S. Fuzzy importance in fault tree analysis. *Fuzzy Sets and Systems* 12 (1984), 205–213.
- [20] GOGUEN, J. A. L-fuzzy sets. *Journal Mathematical Analysis and Applications* 18 (1967), 145–174.
- [21] GUPTA, M. M., SARIDIS, G. N., AND GAINES, B. R., Eds. *Fuzzy Automata and Decision Processes*. North-Holland Publishers, Amsterdam, 1977.
- [22] HAUGEN, E. B. *Probabilistic Mechanical Design*. John Wiley and Sons, New York, NY, 1980.
- [23] KAUFMANN, A., AND GUPTA, M. M. *Introduction to Fuzzy Arithmetic: Theory and Applications*. Electrical/Computer Science and Engineering Series. Van Nostrand Reinhold Company, New York, 1985.
- [24] KUBIC, W. L., AND STEIN, F. P. A theory of design reliability using probability and fuzzy sets. *AIChE Journal* 34, 4 (Apr. 1988), 583–601.
- [25] LEUNG, K. S., AND LAM, W. Fuzzy concepts in expert systems. *Computer* 21, 9 (Sept. 1988), 43–56.
- [26] MEUNIER, K. L., AND DIXON, J. R. Iterative respecification: A computational model for hierarchical mechanical system design. In *Computers in Engineering 1988* (New York, NY, June 1988), V. A. Tipnis and E. M. Patton, Eds., ASME, pp. 25–32.
- [27] MOORE, R. E. *Methods and Applications of Interval Analysis*. Society for Industrial and Applied Mathematics, Philadelphia, PA, 1979.
- [28] PAHL, G., AND BEITZ, W. *Engineering Design*. The Design Council, Springer-Verlag, New York, NY, 1984.
- [29] RAO, S. S. Description and optimum design of fuzzy mechanical systems. *ASME Journal of Mechanisms, Transmissions, and Automation in Design* (1986), 1–7.
- [30] REKLAITIS, G. V., RAVINDRAN, A., AND RAGSDALL, K. M. *Engineering Optimization, Methods and Applications*. Wiley, New York, NY, 1983.



- [31] SIDDALL, J. N. *Probabilistic Engineering Design; Principles and Applications*. Marcel Dekker, New York, NY, 1983.
- [32] TAGUCHI, G. *Introduction to Quality Engineering*. Asian Productivity Organization, Unipub, White Plains, NY, 1986.
- [33] WOOD, K. L., AND ANTONSSON, E. K. A Fuzzy Sets Approach to Computational Tools for Preliminary Engineering Design. In *Advances in Design Automation - 1987, Volume One: Design Methods, Computer Graphics, and Expert Systems – DE-Vol. 10-1* (New York, Sept. 1987), S. S. Rao, Ed., ASME, pp. 263–271.
- [34] WOOD, K. L., AND ANTONSSON, E. K. Computations with Imprecise Parameters in Engineering Design: Application and Example. *ASME Journal of Mechanisms, Transmissions, and Automation in Design* (June 1988).
- [35] WOOD, K. L., ANTONSSON, E. K., AND BECK, J. L. Comparing Fuzzy and Probability Calculus for Representing Imprecision in Preliminary Engineering Design. In *Design Theory and Methodology - 1989* (New York, Sept. 1989), W. P. Seering, Ed., ASME, pp. 99–105. Presented at the First International ASME *Design Theory and Methodology Conference* (DTM '89), September 18-19, 1989, Montréal, Canada.
- [36] YAGER, R. Satisfaction and fuzzy decision functions. In *Theory and Applications to Policy Analysis and Information Systems*, P. P. Wang and S. K. Chang, Eds. Plenum Press, New York, 1980.
- [37] YAO, J. T. P. Application of fuzzy sets in fatigue and fracture reliability. Communication Dr. Housner Caltech, 1979.
- [38] ZADEH, L. A. Fuzzy sets. *Information and Control* 8 (1965), 338–353.
- [39] ZADEH, L. A. Outline of a new approach to the analysis of complex systems and decision processes. *IEEE Transactions on Systems, Man, and Cybernetics* 3, 1 (1973), 29–44.
- [40] ZADEH, L. A. The concept of a linguistic variable and its application to approximate reasoning – I. *Information Sciences* 8 (1975), 199–249.
- [41] ZADEH, L. A. Fuzzy logic and approximate reasoning. *Synthese* 30 (1975), 407–428.
- [42] ZADEH, L. A., FU, K. S., TANAKA, K., AND SHIMURA, M., Eds. *Fuzzy Sets and their Applications to Cognitive and Decision Processes*. Academic Press, New York, NY, 1975.
- [43] ZIMMERMANN, H.-J. *Fuzzy Set Theory - and Its Applications*. Management Science/Operations Research. Kluwer-Nijhoff Publishing, Boston, MA, 1985.